



**GMTCNT STEP MOTORLAR**  
**MODEL: GSTM11018-150-460**  
**Kullanım Kılavuzu**



**Dikkat !**

**Cihazı kullanmadan önce kullanma kılavuzunu dikkatlice okuyunuz!**

Kullanma kılavuzundaki uyarılara uyulmamasından kaynaklanan zarar, ziyan ve şahısların uğrayacağı kazalarda sorumluluk kullanıcıya aittir. Bu durumda oluşan arızalarda cihaz garanti kapsamından çıkar.

**GMTCNT**

**GMT ENDÜSTRİYEL ELEKTRONİK SAN. VE TİC. LTD. ŞTİ.**

Çubuklu Mahallesi Boğaziçi Caddesi No:6/B 34805 Beykoz / İstanbul / Türkiye

T +90 (216) 668 00 06

Web site: <http://www.gmtcontrol.com/>

F +90 (216) 668 00 03

E-Mail: [gmt@gmtcontrol.com](mailto:gmt@gmtcontrol.com)

**1. Teknik Özellikler**

Model	L(mm)	N.m	A	Mil Çapı (mm)
GSTM11018-150-460	150	20	6	19

**2. Mekanik Çizim (mm)**

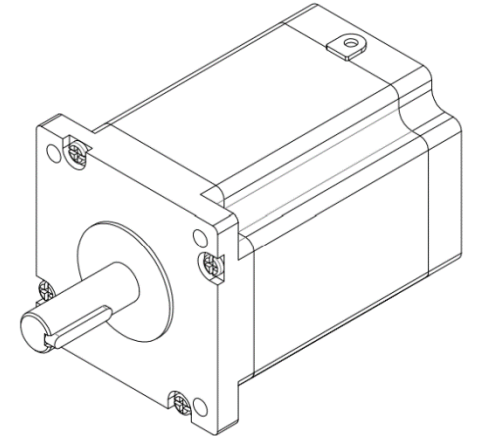
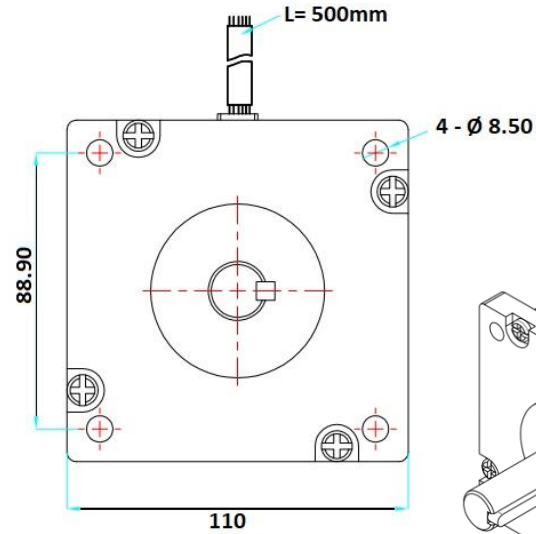
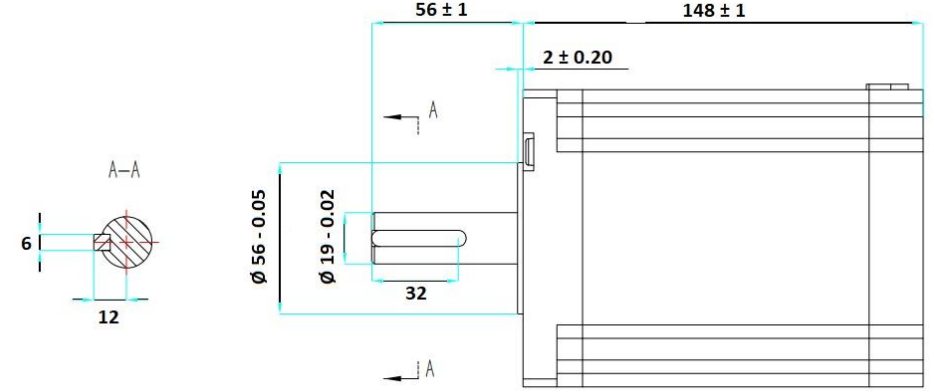

### 3. Bağlantı Diyagramı

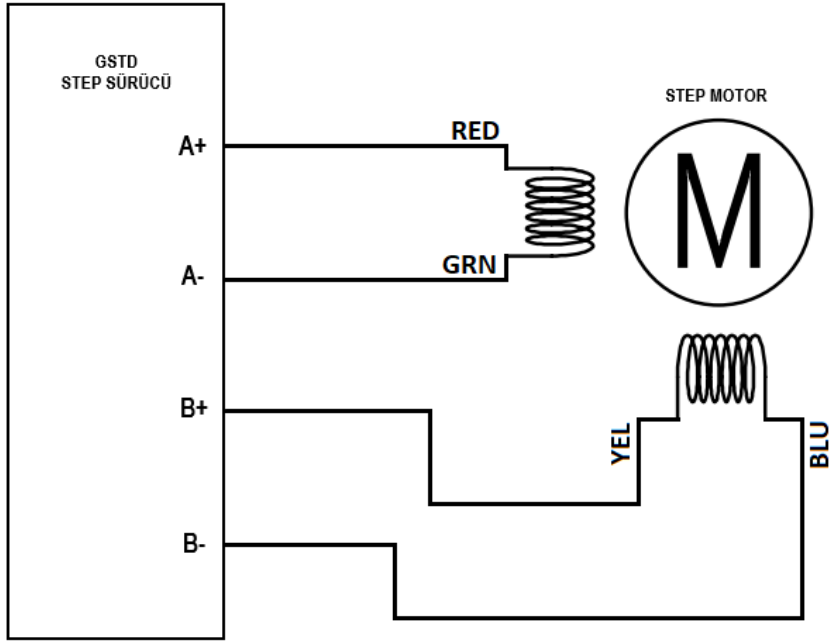

### 4. Step Motor Tork-Hız Eğrileri

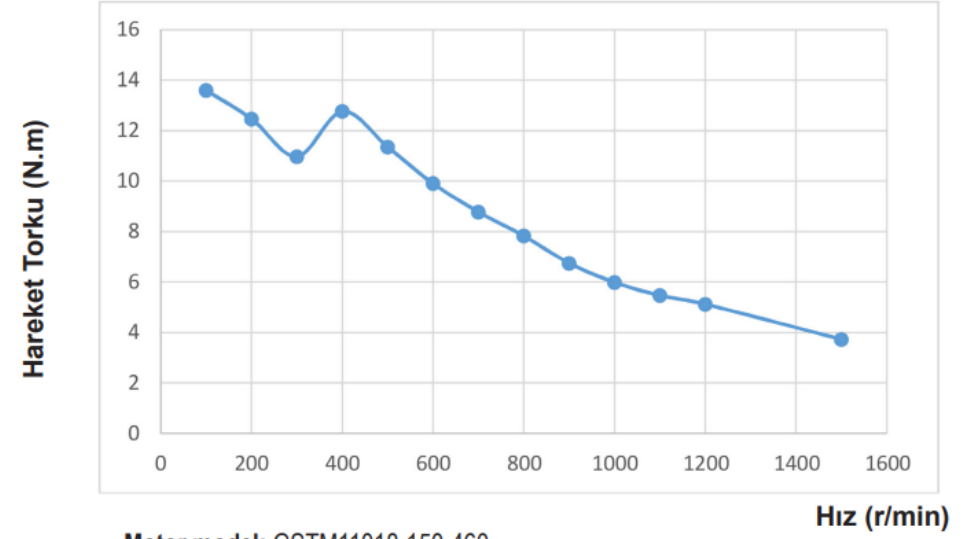

- Motor model: GSTM11018-150-460
- Test voltage: 220VAC
- Motor: Parallel connection
- Test driver: GSTD22280
- Test microstep: 8 (1600 PPR)
- Test current: 4.0 A (RMS)