

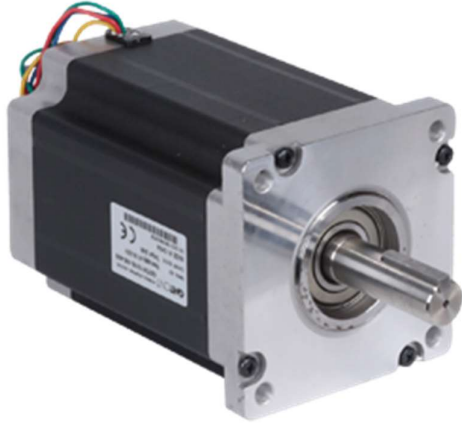

GMTCNT STEP MOTORLAR
MODEL: GSTM11018-165-460
Kullanım Kılavuzu



Dikkat !

Cihazı kullanmadan önce kullanma kılavuzunu dikkatlice okuyunuz!
Kullanma kılavuzundaki uyarılara uyulmamasından kaynaklanan zarar, ziyan ve şahısların uğrayacağı kazalarda sorumluluk kullanıcıya aittir. Bu durumda oluşan arızalarda cihaz garanti kapsamından çıkar.

GMTCNT

GMT ENDÜSTRİYEL ELEKTRONİK SAN. VE TİC. LTD. ŞTİ.

Çubuklu Mahallesi Boğaziçi Caddesi No:6/B 34805 Beykoz / İstanbul / Türkiye

T +90 (216) 668 00 06

Web site: <http://www.gmtcontrol.com/>

F +90 (216) 668 00 03

E-Mail: gmt@gmtcontrol.com

1. Teknik Özellikler

Model	L(mm)	N.m	A	Mil Çapı (mm)
GSTM11018-165-460	160	24	6	19

2. Mekanik Çizim (mm)

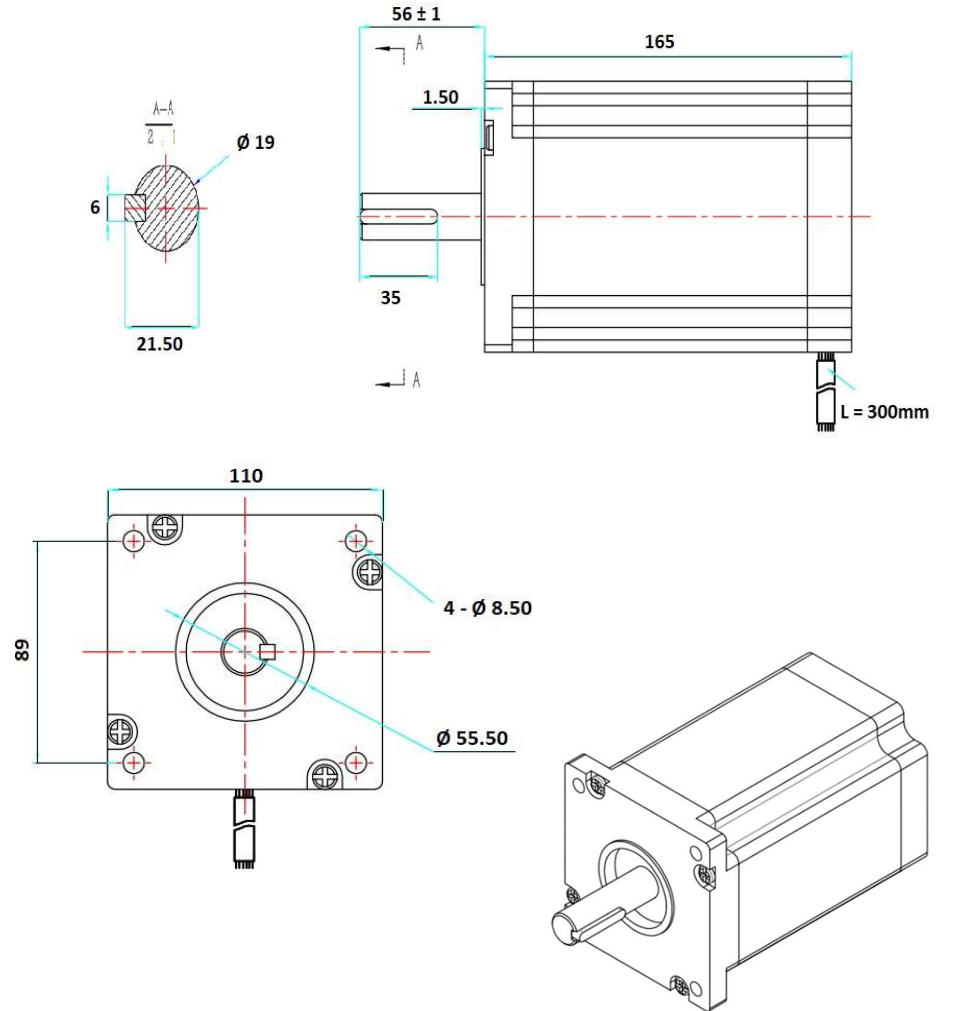

3. Bağlantı Diyagramı

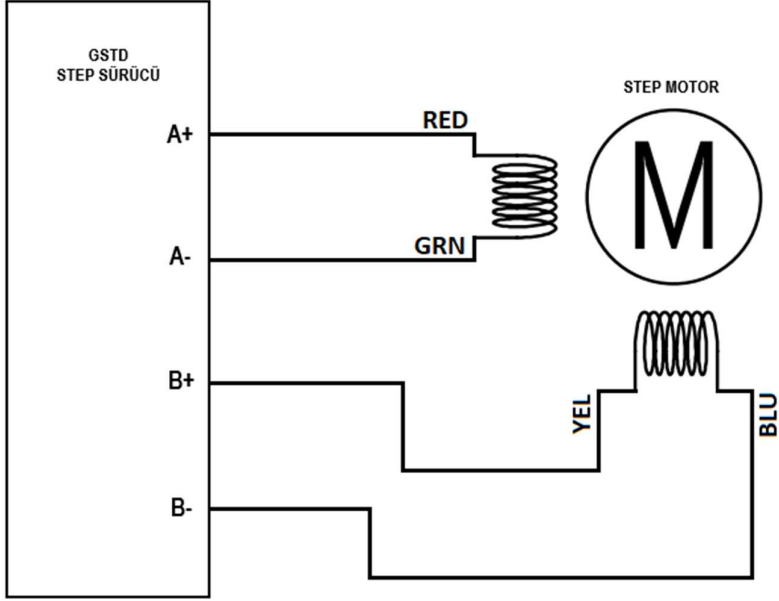

4. Step Motor Torque - Hız Eğrileri

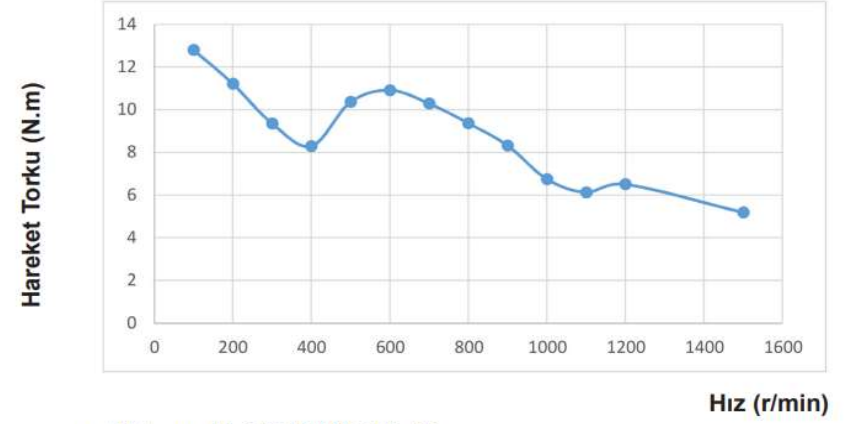

- **Motor model:** GSTM11018-165-460
- **Test voltage:** 80 VAC
- **Motor:** Parallel connection
- **Test driver:** GSTD22280
- **Test microstep:** 8 (1600 PPR)
- **Test current:** 4.0 A (RMS)

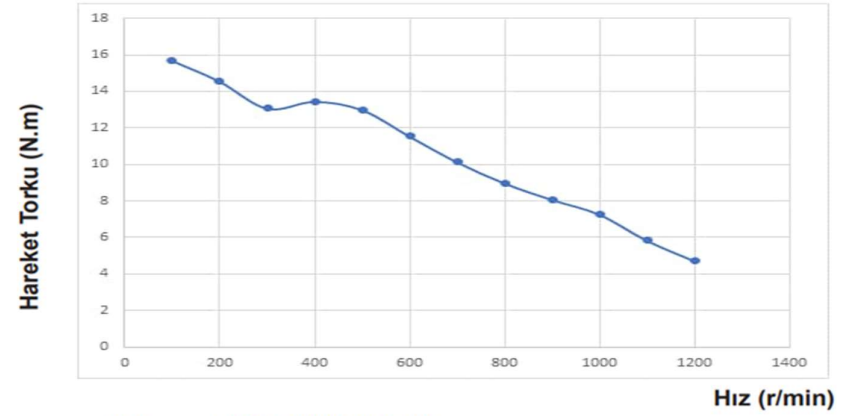

- **Motor model:** GSTM11018-165-460
- **Test voltage:** 220 VAC
- **Motor:** Parallel connection
- **Test driver:** GSTD22280
- **Test microstep:** 8 (1600 PPR)
- **Test current:** 4.0 A (RMS)